

T2 Selection and Installation Guide



1) Select valve body and orifice size

T2 type expansion valves are designed for flare connections. To make a functioning valve, pair the appropriate valve body and orifice using the charts below.

IF THE EXACT SYSTEM CAPACITY CANNOT BE FOUND, USE THE NEXT LARGER ORIFICE.

2) Assemble the orifice and valve body and install into system Orifice and System Installation

- Slide the orifice into the valve body and secure using liquid line flare nut.
- Attach evaporator inlet or distributor assembly to valve outlet flare nut.

Tighten both flare nuts to 26 - 33 lbs.

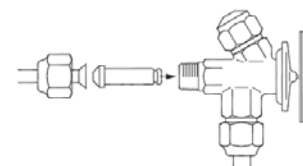

Torque Requirements

26-33 ft-lb
(35-45Nm)

Superheat Adjustment

- Remove the cap.
- Make superheat adjustments ¼ turn at a time (1 turn=7°F). Turning clockwise increases superheat. Turning counter-clockwise decreases superheat.
- Reinstall the cap.

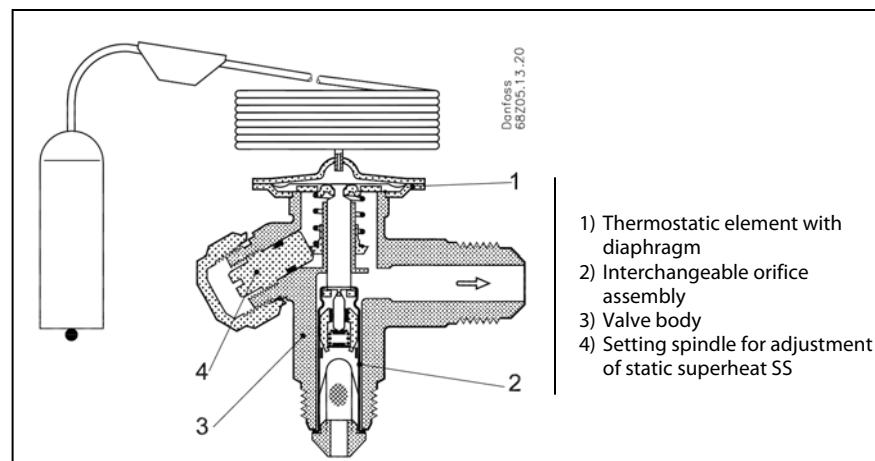

- 1) Thermostatic element with diaphragm
- 2) Interchangeable orifice assembly
- 3) Valve body
- 4) Setting spindle for adjustment of static superheat SS

R22			Evap. Temperature (°F)								
Valve Body ¹	Orifice Size	Code Number	45	35	25	0	-10	-20	-30	-40	
			Rated Capacity in Tons (TR) ²								
TX 2 068Z3206	TEX 2 068Z3209	0x	068-2002	1/10 1/8	1/10 1/8	1/10 1/8	1/10 1/8	1/10 1/8	1/10 1/8	1/10 1/8	
		00	068-2003	1/6 1/4	1/6 1/4	1/6 1/4	1/6 1/4	1/6 1/4	1/6 1/4	1/6 1/4	
		01	068-2010	1/2 3/4	1/2 3/4	1/2 3/4	1/2	1/2	1/2	1/4	1/4
		02	068-2015	1	1	1	3/4 1 1/2	3/4	3/4	1/2	1/2
		03	068-2006	2	2	2	1 1 1/2	1	1	3/4 1	3/4 1
		04	068-2007	3	3	3	2	2	2	1 1/2	1 1/2
		05	068-2008	4	4	3 1/2	3	2 1/2	2 1/2	2	2
06	068-2009	5	5	4 1/2	3 1/2	3	3	2 1/2	2 1/2		

R404A / R507			Evap. Temperature (°F)								
Valve Body ¹	Orifice Size	Code Number	45	35	25	0	-10	-20	-30	-40	
			Rated Capacity in Tons (TR) ²								
TS2 068Z3400	TES 2 068Z3403	0x	068-2002	1/10 1/8	1/10 1/8	1/10 1/8	1/10 1/8	1/10 1/8	1/10 1/8	1/15	
		00	068-2003	1/6 1/4	1/6 1/4	1/6 1/4	1/6 1/4	1/6 1/4	1/6 1/4	1/6 1/8	
		01	068-2010	1/2	1/4 1/2	1/4	1/4	1/4	1/4	1/4	1/6
		02	068-2015	3/4	1/2	1/2	1/2	1/4	1/4	1/4	1/4
		03	068-2006	1	3/4 1	3/4 1	3/4	1/2 3/4	1/2	1/2	1/2
		04	068-2007	2	2	1 1/2	1	1	3/4 1	3/4	3/4
		05	068-2008	2 1/2	2	2	1 1/2	1 1/2	1	1	1
06	068-2009	3	3	2 1/2	2	1 1/2	1 1/2	1	1		

R134a			Evap. Temperature (°F)								
Valve Body ¹	Orifice Size	Code Number	45	35	25	0	-10	-20	-30	-40	
			Rated Capacity in Tons (TR) ²								
TN 2 068Z3346	TEN 2 068Z3348	0x	068-2002	1/10 1/8	1/10 1/8	1/10 1/8	1/10	1/10	1/10	1/10	
		00	068-2003	1/6 1/4	1/6	1/6	1/6 1/8	1/6 1/8	1/6 1/8	1/6 1/8	
		01	068-2010	1/2	1/4 1/2	1/4	1/4	1/4	1/4	1/6	1/6
		02	068-2015	3/4	1/2	1/2	1/2	1/4	1/4	1/4	1/4
		03	068-2006	1	3/4 1	3/4 1	3/4	1/2 3/4	1/2	1/2	1/2
		04	068-2007	2	1 1/2	1 1/2	1	1	3/4	3/4	3/4
		05	068-2008	2 1/2	2	2	1 1/2	1	1	1	1
06	068-2009	3	2 1/2	2 1/2	2	1 1/2	1 1/2	1	1		

¹ Valve Body - Internal: 3/8" X 1/2" ODF - External: 3/8" X 1/2" w/ 1/4" ODF Equalizer

² Capacities are based on a condensing temperature of 90 °F and a vapor free liquid temperature of 80 °F ahead of the expansion valve.